

Operating Manual

Keysight 1182B Testmobile Instrument Cart

Notices

© Keysight Technologies, Inc. 2015

No part of this manual may be reproduced in any form or by any means (including electronic storage and retrieval or translation into a foreign language) without prior agreement and written consent from Keysight Technologies, Inc. as governed by United States and international copyright laws.

Manual Part Number

5967-9303

Edition

Third Edition, August 2015

Printed in

Malaysia

Published by

Keysight Technologies, Inc.
900 S. Taft Ave.
Loveland, CO 80537 USA

Trademarks

PICMG[®], Compact PCI[®] are registered trademarks of the PCI Industrial Computer Manufacturers Group.

AdvancedTCA[®] and ATCA are registered trademarks of the PCI Industrial Computer Manufacturers Group.

PCI-SIG[®], PCI Express[®], and PCIe[®] are registered trademarks of PCI-SIG.

Technology Licenses

The hardware and/or software described in this document are furnished under a license and may be used or copied only in accordance with the terms of such license.

Declaration of Conformity

Declarations of Conformity for this product and for other Keysight products may be downloaded from the Web. Go to <http://keysight.com/go/conformity>.

You can then search by product number to find the latest Declaration of Conformity.

U.S. Government Rights

The Software is “commercial computer software,” as defined by Federal Acquisition Regulation (“FAR”) 2.101. Pursuant to FAR 12.212 and 27.405-3 and Department of Defense FAR Supplement (“DFARS”) 227.7202, the U.S. government acquires commercial computer software under the same terms by which the software is customarily provided to the public. Accordingly, Keysight provides the Software to U.S. government customers under its standard commercial license, which is embodied in its End User License Agreement (EULA), a copy of which can be found at <http://www.keysight.com/find/sweula>. The license set forth in the EULA represents the exclusive authority by which the U.S. government may use, modify, distribute, or disclose the Software. The EULA and the license set forth therein, does not require or permit, among other things, that Keysight: (1) Furnish technical information related to commercial computer software or commercial computer software documentation that is not customarily provided to the public; or (2) Relinquish to, or otherwise provide, the government rights in excess of these rights customarily provided to the public to use, modify, reproduce, release, perform, display, or disclose commercial computer software or commercial computer software documentation. No additional government requirements beyond those set forth in the EULA shall apply, except to the extent that those terms, rights, or licenses are explicitly required from all providers of commercial computer software pursuant to the FAR and the DFARS and are set forth specifically in writing elsewhere in the EULA. Keysight shall be under no obligation to update, revise or otherwise modify the Software. With respect to any technical data as defined by FAR 2.101, pursuant to FAR 12.211 and 27.404.2 and DFARS 227.7102, the U.S. government acquires no greater than Limited Rights as defined in FAR 27.401 or DFAR 227.7103-5 (c), as applicable in any technical data.

Warranty

THE MATERIAL CONTAINED IN THIS DOCUMENT IS PROVIDED “AS IS,” AND IS SUBJECT TO BEING CHANGED, WITHOUT NOTICE, IN FUTURE EDITIONS. FURTHER, TO THE MAXIMUM EXTENT PERMITTED BY APPLICABLE LAW, KEYSIGHT DISCLAIMS ALL WARRANTIES, EITHER EXPRESS OR IMPLIED, WITH REGARD TO THIS MANUAL AND ANY INFORMATION CONTAINED HEREIN, INCLUDING BUT NOT LIMITED TO THE IMPLIED WARRANTIES OF MERCHANTABILITY AND FITNESS FOR A PARTICULAR PURPOSE. KEYSIGHT SHALL NOT BE LIABLE FOR ERRORS OR FOR INCIDENTAL OR CONSEQUENTIAL DAMAGES IN CONNECTION WITH THE FURNISHING, USE, OR PERFORMANCE OF THIS DOCUMENT OR OF ANY INFORMATION CONTAINED HEREIN. SHOULD KEYSIGHT AND THE USER HAVE A SEPARATE WRITTEN AGREEMENT WITH WARRANTY TERMS COVERING THE MATERIAL IN THIS DOCUMENT THAT CONFLICT WITH THESE TERMS, THE WARRANTY TERMS IN THE SEPARATE AGREEMENT SHALL CONTROL.

Keysight Technologies does not warrant third-party system-level (combination of chassis, controllers, modules, etc.) performance, safety, or regulatory compliance unless specifically stated.

Safety Information

CAUTION

A CAUTION denotes a hazard. It calls attention to an operating procedure or practice that, if not correctly performed or adhered to, could result in damage to the product or loss of important data. Do not proceed beyond a CAUTION notice until the indicated conditions are fully understood and met.

WARNING

A WARNING denotes a hazard. It calls attention to an operating procedure or practice, that, if not correctly performed or adhered to, could result in personal injury or death. Do not proceed beyond a WARNING notice until the indicated conditions are fully understood and met.

Safety Information

The following general safety precautions must be observed during all phases of operation of this instrument. Failure to comply with these precautions or with specific warnings or operating instructions in the product manuals violates safety standards of design, manufacture, and intended use of the instrument. Keysight Technologies assumes no liability for the customer's failure to comply with these requirements.

General

Do not use this product in any manner not specified by the manufacturer. The protective features of this product must not be impaired if it is used in a manner specified in the operation instructions.

Before Applying Power

Verify that all safety precautions are taken. Make all connections to the unit before applying power. Note the external markings described under "Safety Symbols".

Ground the Instrument

Keysight chassis' are provided with a grounding-type power plug. The instrument chassis and cover must be connected to an electrical ground to minimize shock hazard. The ground pin must be firmly connected to an electrical ground (safety ground) terminal at the power outlet. Any interruption of the protective (grounding) conductor or disconnection of the protective earth terminal will cause a potential shock hazard that could result in personal injury.

Do Not Operate in an Explosive Atmosphere

Do not operate the module/chassis in the presence of flammable gases or fumes.

Do Not Operate Near Flammable Liquids

Do not operate the module/chassis in the presence of flammable liquids or near containers of such liquids.

Cleaning

Clean the outside of the Keysight module/chassis with a soft, lint-free, slightly dampened cloth. Do not use detergent or chemical solvents.

Do Not Remove Instrument Cover

Only qualified, service-trained personnel who are aware of the hazards involved should remove instrument covers. Always disconnect the power cable and any external circuits before removing the instrument cover.

Keep away from live circuits

Operating personnel must not remove equipment covers or shields. Procedures involving the removal of covers and shields are for use by service-trained personnel only. Under certain conditions, dangerous voltages may exist even with the equipment switched off. To avoid dangerous electrical shock, DO NOT perform procedures involving cover or shield removal unless you are qualified to do so.

DO NOT operate damaged equipment

Whenever it is possible that the safety protection features built into this product have been impaired, either through physical damage, excessive moisture, or any other reason, REMOVE POWER and do not use the product until safe operation can be verified by service-trained personnel. If necessary, return the product to an Keysight Technologies Sales and Service Office for service and repair to ensure the safety features are maintained.

DO NOT block the primary disconnect

The primary disconnect device is the appliance connector/power cord when a chassis used by itself, but when installed into a rack or system the disconnect may be impaired and must be considered part of the installation.

Do Not Modify the Instrument

Do not install substitute parts or perform any unauthorized modification to the product. Return the product to an Keysight Sales and Service Office to ensure that safety features are maintained.

In Case of Damage

Instruments that appear damaged or defective should be made inoperative and secured against unintended operation until they can be repaired by qualified service personnel

CAUTION

Do NOT block vents and fan exhaust: To ensure adequate cooling and ventilation, leave a gap of at least 50mm (2") around vent holes on both sides of the chassis.

Do NOT operate with empty slots: To ensure proper cooling and avoid damaging equipment, fill each empty slot with an AXle filler panel module.

Do NOT stack free-standing chassis: Stacked chassis should be rack-mounted.

All modules are grounded through the chassis: During installation, tighten each module's retaining screws to secure the module to the chassis and to make the ground connection.

WARNING

Operator is responsible to maintain safe operating conditions. To ensure safe operating conditions, modules should not be operated beyond the full temperature range specified in the Environmental and physical specification. Exceeding safe operating conditions can result in shorter lifespan, improper module performance and user safety issues. When the modules are in use and operation within the specified full temperature range is not maintained, module surface temperatures may exceed safe handling conditions which can cause discomfort or burns if touched. In the event of a module exceeding the full temperature range, always allow the module to cool before touching or removing modules from the chassis.

Safety Symbols







CAUTION

A CAUTION denotes a hazard. It calls attention to an operating procedure or practice, that, if not correctly performed or adhered to could result in damage to the product or loss of important data. Do not proceed beyond a CAUTION notice until the indicated conditions are fully understood and met.

WARNING

A WARNING denotes a hazard. It calls attention to an operating procedure or practice, that, if not correctly performed or adhered to, could result in personal injury or death. Do not proceed beyond a WARNING notice until the indicated conditions are fully understood and met.

Products display the following symbols:

-  Warning, risk of electric shock
-  Refer to manual for additional safety information.
-  Earth Ground.
-  Chassis Ground.
-  Alternating Current (AC).
-  Standby Power. Unit is not completely disconnected from AC mains when switch is in standby.
-  Antistatic precautions should be taken.
- CAT I IEC Measurement Category I, II, III, or IV
- CAT II
- CAT III
- CAT IV

For localized Safety Warnings, Refer to Keysight Safety document (p/n 9320-6792).



The CSA mark is a registered trademark of the Canadian Standards Association and indicates compliance to the standards laid out by them. Refer to the product Declaration of Conformity for details.



Notice for European Community: This product complies with the relevant European legal Directives: EMC Directive (2004/108/EC) and Low Voltage Directive (2006/95/EC).



The Regulatory Compliance Mark (RCM) mark is a registered trademark. This signifies compliance with the Australia EMC Framework regulations under the terms of the Radio Communication Act of 1992.

ICES/NMB-001

ICES/NMB-001 indicates that this ISM device complies with the Canadian ICES-001.



This symbol represents the time period during which no hazardous or toxic substance elements are expected to leak or deteriorate during normal use. Forty years is the expected useful life of this product.



South Korean Class A EMC Declaration. This equipment is Class A suitable for professional use and is for use in electromagnetic environments outside of the home.

A 급 기기 (업무용 방송통신기자재) 이 기기는 업무용 (A 급) 전자파적합기기로서 판매자 또는 사용자는 이 점을 주의하시기 바라 며 , 가정외의 지역에서 사용하는 것을 목적으로 합니다.



Waste Electrical and Electronic Equipment (WEEE) Directive 2002/96/EC

This product complies with the WEEE Directive (2002/96/EC) marking requirement. The affixed product label (see below) indicates that you must not discard this electrical/electronic product in domestic household waste.

Product Category: With reference to the equipment types in the WEEE directive Annex 1, this product is classified as a "Monitoring and Control instrumentation" product.

Do not dispose in domestic household waste.

To return unwanted products, contact your local Keysight office for more information.



Contents

Description	6
Initial Inspection	6
Assembly Instructions	7
Assemble the Retaining Straps	7
Instrument Mounting	7
To Mount the Instrument on the Cart	8
Operating the Tilt Tray	8
To Set the Tilt Tray	8
Accessories	10
Specifications	11
Replaceable Parts	12

Description

Description

The Keysight Technologies Model 1182B Testmobile instrument cart provides convenient movability for your instruments. It allows you to easily view and use the instrument while seated at a work station or bench. You can tilt the instrument up to 30 degrees for viewing comfort. A nylon strap is provided to secure the instrument to the cart.

The Keysight 1182B casters have mar-resistant hard rubber tiers. The rear wheels have locking brakes. The tilt tray is designed to be used with instruments that weigh up to 150 lbs.

Initial Inspection

Inspect the shipping container for damage. If there is apparent damage to the shipping container or packaging materials, do not discard these materials until the Testmobile cart has been inspected for damage. If it has been damaged in shipment, notify the carrier and the nearest Keysight Technologies Sales/Service office.

Assembly Instructions

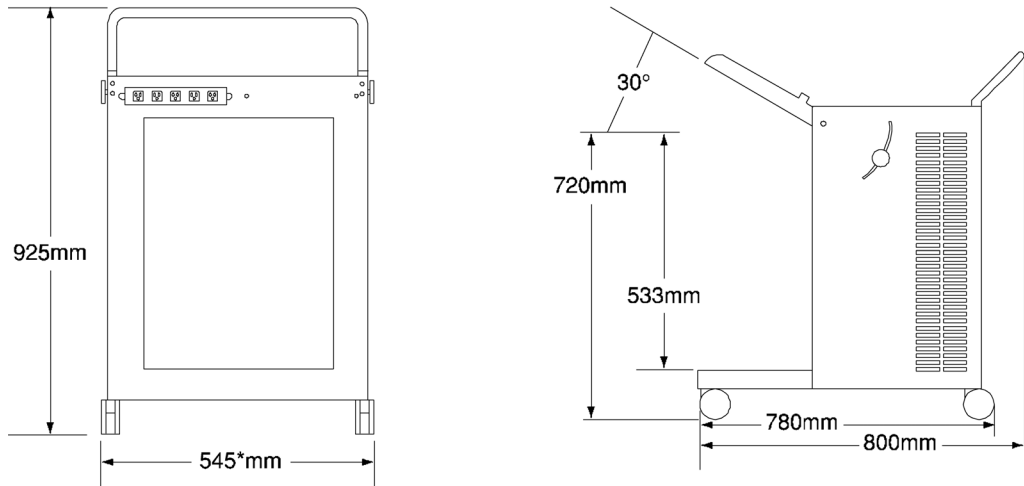

Figure 1 Testmobile cart back view and side view.

Assemble the Retaining Straps

Attach the retaining strap on the slots of the instrument tray. Thread the strap through the buckle. Attach the power strip (optional).

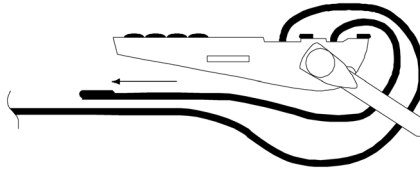

Figure 2 Inserting the strap in the fastener.

Instrument Mounting

WARNING

Observe load and center-of-gravity limits. Do not sit or stand on cart. Max load, top tray: 68.2 (150 lbs.) Max load, total: 159.1 kg (350 lbs.)

Overall width increases to 602 mm when the work surface is installed.

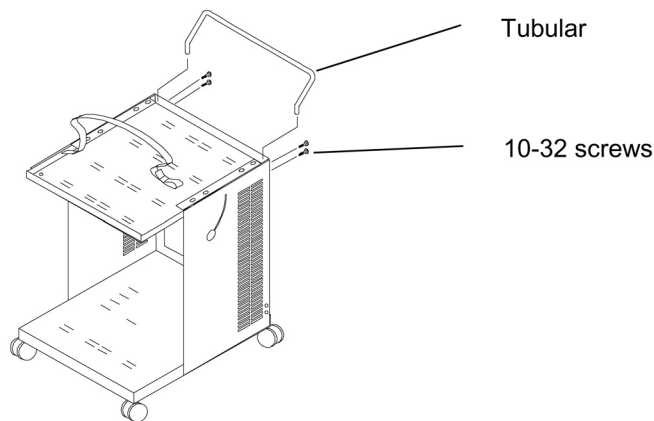

Figure 3 Testmobile cart with hold down strap in place, showing how to install the handle.

To Mount the Instrument on the Cart

Center the instrument on the tilt tray. Insert the plastic tabs that are located in front of the instrument legs in the appropriate slots of the testmobile cart.

CAUTION

Do not place the metal front legs of the instrument in an upright position. Allow the instrument to rest on all four anti-skid hard rubber feet secured with the tabs in the slots. Place the retaining strap over the top of the instrument. Hold the fastener in the hook and thread the strap through the fastener (see figure on previous page).

Operating the Tilt Tray

CAUTION

Do not force the fastener closed. If it is difficult to close the fastener, loosen the strap and allow slightly more slack. When adjusted properly, the fastener should close with little effort.

The tilt tray is adjustable from 0 to 30 degrees. This allows you to select a comfortable viewing angle. The cart is equipped with a knob on each side of the cabinet used to tighten and secure the desired angle of the tilt tray.

To Set the Tilt Tray

Loosen the knobs on each side of the cabinet. Set the desired angle. Tighten both knobs to secure the tray position.

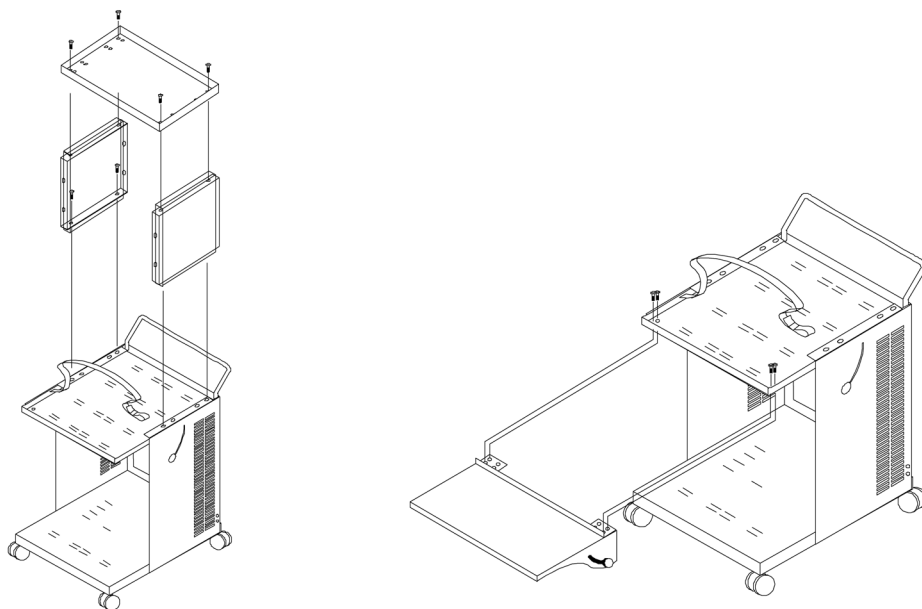

Figure 4 Left, Testmobile cart with hold down strap in place, showing optional accessories 92199B Multiple Outlet Strip and the 35181H Printer/Plotter Stand. Right, Testmobile shown with Keysight 35181K Work Surface.

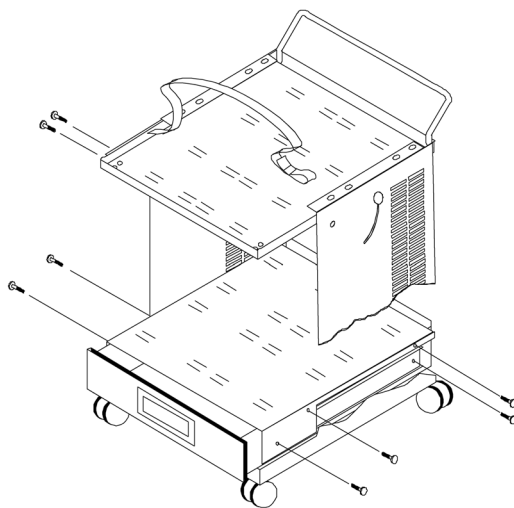

Figure 5 Keysight 35182C 89 mm (3.5 inch) drawer and storage shelf. Hardware included.

Accessories

The following accessories are available for the Keysight 1182B Testmobile cart:

P/N	Product Descriptions
35181H	Top mounted printer/plotter stand
35182N	3.5 high support shelf/storage drawer
35181K	Work surface
92199B	Multiple outlet strip (U.S. & Canada only)
92199E	Multiple IEC-320 outlet strip (International, requires cable assembly below)
8120-1575	Cable, 762.0 mm (30 in) long (for 92199E)
8120-1860	Cable, 1,524 mm (60 in) long (for 92199E)
8120-2191	Cable, 1,524 mm (60 in) long with 90 degree plug (for 92199E)
5181-8707	IEC-320 Male power cable adapter

Specifications

Dimensions:	925 mm H x 545 mm W x 800 mm D (36.4 in H x 21.5 in W x 31.5 in D)
Wheel Size	127.0 mm (5 inches) diameter. All wheels lock.
Tilt angle of tray:	30 degrees maximum
Load limits of tray:	68.2 kg (150 lbs.)
Load limits of cart:	159.1 kg (350 lbs.)

Replaceable Parts

To order a replacement part, address an order to the nearest Keysight Technologies Sales/Service Office, specify the Keysight part number and quantity for each part.

There are two replaceable parts for the Keysight 1182B:

Part Number	Description	Quantity Per
1530-2228	Tie-down	1
1492-0160	Caster, swivel	1

NOTE

The Keysight 1182B has mounting provisions for the Keysight 921199B/E power strips. For off-theshelf shipment of the power strips, call 1-800-452-4844.

Overall width is 602 mm (23.7 in) when the work surface is in use.

Overall width is 570 mm (22.4 in) when the printer/plotter stand is in use



This information is subject to change
without notice
© Keysight Technologies 2015
Edition 3 August 2015
Published in USA



5967-9303
www.keysight.com